

ALLROUNDER 470 C 1500

Technical data

Tie bar distance: 470 x 470 mm

Clamping force: 1500 kN

Injection units (according to EUROMAP): 350, 800

ARBURG

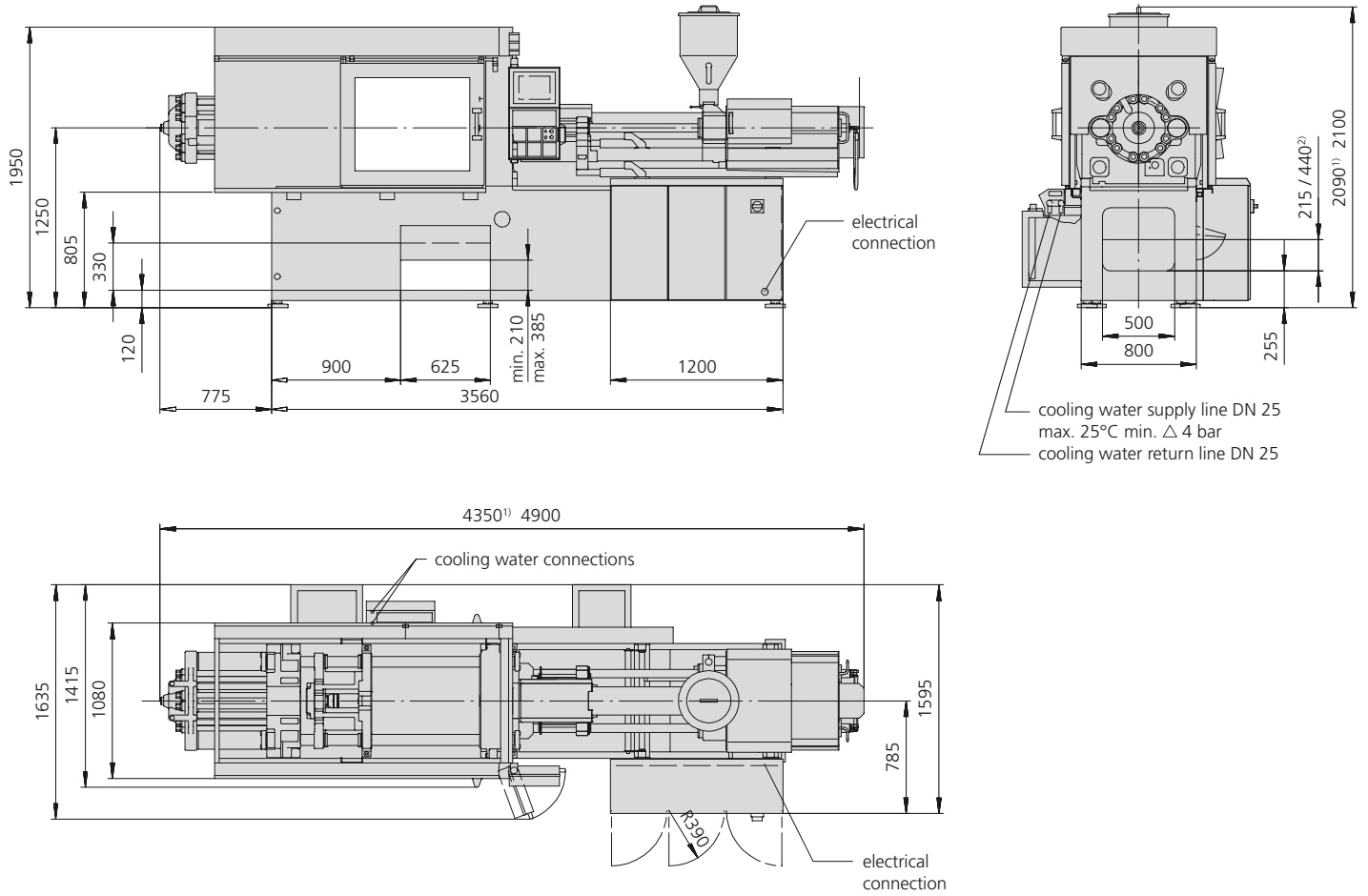

1) Dimensions apply for 470 C 1500-350
 2) Dimension only valid in conjunction with conveyor belt

| Machine model | | 470 C | 470 C |
|---|-------------------------|--------------------|--------------------|
| EUROMAP size indication ¹⁾ | | 1500-350 | 1500-800 |
| Clamping unit | | | |
| Clamping force | max. kN | 1500 | 1500 |
| Closing force | max. kN | 50 | 50 |
| Opening force / increased | max. kN | 35 / 350 | 35 / 350 |
| Opening stroke | max. mm | 500 | 500 |
| Mould height | min. mm | 250 | 250 |
| Daylight | max. mm | 750 | 750 |
| Distance between tie bars | mm | 470 x 470 | 470 x 470 |
| Platen size (hor. x vert.) | mm | 650 x 650 | 650 x 650 |
| Weight of mov. mould half | max. kg | 800 | 800 |
| Ejector force | max. kN | 40 | 40 |
| Ejector stroke | max. mm | 175 | 175 |
| Hydraulics, drive, general | | | |
| Drive power of the hydraulic pump | kW | 30 | 30 |
| Dry cycle time for opening stroke ³⁾ | s-mm | 1,9-329 | 1,9-329 |
| Total connected load ²⁾ | kW | 41,9 | 46,3 |
| Colour: plastic coated, structure light grey / mint green / canary yellow | | | |
| Control cabinet | | | |
| Safety standard according to | | DIN EN 60204 | DIN EN 60204 |
| Socket combination (1 single phase, 1 three-phase) | | 1 x 16 A | 1 x 16 A |
| Injection unit | | 350 | 800 |
| Screw diameter | mm | 35 / 40 / 45 | 45 / 50 / 55 |
| Effective screw length | L/D | 23 / 20 / 18 | 22 / 20 / 18 |
| Screw stroke | max. mm | 145 | 200 |
| Calculated injection volume | max. cm ³ | 139 / 182 / 230 | 318 / 392 / 474 |
| Shot weight | max. g PS | 127 / 166 / 210 | 291 / 359 / 434 |
| Material throughput ⁵⁾ | max. kg/h PS | 25 / 29 / 35 | 46 / 53 / 59 |
| | max. kg/h PA 6.6 | 12,5 / 15 / 17,5 | 23 / 27 / 30 |
| Injection pressure ⁴⁾ | max. bar | 2500 / 2120 / 1670 | 2470 / 2000 / 1650 |
| Injection flow ⁴⁾ | max. cm ³ /s | 160 / 210 / 266 | 174 / 214 / 260 |
| Injection flow with accumulator | max. cm ³ /s | 492 / 642 / 814 | 530 / 656 / 792 |
| Back pressure positive / negative | max. bar | 350 / 160 | 350 / 190 |
| Circumferential screw speed | max. m/min | 58 / 67 / 75 | 56 / 62 / 69 |
| Screw torque | max. Nm | 480 / 550 / 610 | 880 / 880 / 880 |
| Nozzle contact force | max. kN | 60 | 70 |
| Nozzle retraction stroke | max. mm | 300 | 400 |
| Installed cylinder heating power / heating zones | kW | 8,8 / 4 | 13,2 / 6 |
| Installed nozzle heating power | kW | 0,6 | 0,6 |
| Material hopper capacity | l | 50 | 50 |
| Horizontal injection position | max. mm | --- | --- |
| Machine dimensions and weights of the basic machine | | | |
| Oil capacity | l | 235 | 235 |
| Net weight | kg | 4560 | 5150 |
| Electrical connection (pre-fused) ²⁾ | A | 100 | 125 |

1) 1st figure: clamping force (kN), 2nd figure: max. dosage volume (cm³) x max. injection pressure (kbar)

2) Values refer to 400 V/50 Hz. The load is symmetrically distributed on three phases. The specified value applies to the basic machine. The connection value can be increased by additional options which may make 2 separate supply lines necessary (motor + controller/heating)

3) According to EUROMAP for basic machine

4) A combination of max. injection pressure and max. injection flow (max. injection capacity) can be mutually exclusive, depending on the equipment-related motor output

5) Deviations are possible depending upon process settings and material type

These technical data specifications refer to the state at the time of printing. We reserve the right to modify specifications in the interest of a continuous program of further development.

Control system and control cabinet

- SELOGICA control system (modular, graphic multi-processor system)
- Available in different language versions
- Language change
- Cycle sequence programming with symbols
- Cycle step display in sequence diagram
- Cycle time diagram
- Swivelling monitor unit, central on the operator's side, with colour monitor
- Process graphics for injection speed, screw stroke and injection pressure
- Quality assurance program with fault evaluation and monitoring chart
- Optimisation and user help, follow-up functions at program end, for freely programmable parameter pages, selectable units
- Modular control cabinet design with self-recognition of plug in circuit board system
- Operating modes:
 - Set up
 - Freely programmed test run
 - Reconfiguration
 - Automatic purging and dosing
- Equipment for switch-over to holding pressure via injection pressure, material pressure with different pressure transducers, or via external switch over signal
- Data set administration via disquette
- Visual warning signal (warning lamp)
- Visual / audible warning signal (flashing light / siren)
- Serial printer interface for hard copy, data record and quality protocol
- Interfaces for: PC keyboard, plotter, robotic system according to EUROMAP 12 or 67, part weighing scale, optical barrier, host processor, AQC, ALLROUNDER@web, colouring unit, LSR dos-

- ing system, INJESTER, container change, wiper unit (brush), THERMOLIFT, hot runner control unit and temperature control units for moulds and cylinder
- Socket combination 1 CEE, 1 Schuko 230 V
- Socket combination 1 CEE, 1 Schuko or 3 CEE, 3 Schuko 230 V with external supply line
- 1 additional heating regulation circuit for the nozzle
- Electric heating regulation circuits for moulds (adaptive) (3, 6, 9, 12, 15, 18); mould heating fused at 10 A
- Fuses for mould heating 16 A
- 4 or 8 freely programmable inputs / outputs
- Core pull programs in many versions integrated in the SELOGICA control system
- Special processes such as injection coining, mould venting, variotherm temperature control, intrusion, marbling
- Monitoring: Freely-programmable position monitoring
- Many individual options for special processes

Machine base and hydraulic system

- Free standing machine base on anti-vibration pads
- Ergonomic protection cover with free access to mould and nozzle
- Space for peripheral devices within floor space
- The hydraulic system operates with two energy-saving variable displacement pumps and a servo valve for pressure and speed regulation
- Expansion to up to 3 hydraulic control circuits
- ARBURG energy saving system AES (rpm changeable for hydraulic pump drive)
- Minimum oil volume, oil change interval every 20,000 hours

- Monitoring of oil level, oil temperature and oil filter contamination
- Fine mesh oil filter in the return line
- Mechanical regulation of hydraulic oil temperature
- Electronic regulation of hydraulic oil temperature. Display and monitoring via screen
- Hydraulic oil preheating program to reduce start-up time
- Separate, continuous oil circulation for additional cooling and filtration
- Manually adjustable, machine-related cooling water circuits with 4 free mould connections
- 6 or 8 free cooling water circuits, manually adjustable
- Programmable, machine and mould-related cooling water circuits
- 1 or 2 central switch-off valves for cooling water
- Conveyor belt (electrically driven), height-adjustable in 3 steps, can be integrated into the machine base with or without sorter unit
- Crane with electric hoist to facilitate mould installation and to swivel or shift the injection unit

Clamping unit

- Centrally applied, fully-hydraulic clamping system with 4 individually-removable tie bars
- Vertical support of the movable mould platens
- Movement profiles for the mould clamping unit are programmable and regulated. They are driven using two-circuit pump technology (Technology stage 2 - servo-regulated). The closing pressure is regulated. Simultaneous movement of nozzle and ejector is possible
- Hydraulic system with 3 regulating pumps for extended simultaneous movements (T3)
- Closing and opening profiles are 4-stage programmable

- Intermediate stop possible when closing and opening
- Regulated hydraulic mould protection with monitoring of mould protection time. Follow-up functions: Open or stop after 1 or 2 activations of mould protection
- Extended mould protection (e.g. for spring loaded moulds). Freely-programmable start and end
- Automatic ramp control during switch-over to a lower speed and during stopping of a movement function
- Hydraulic ejector with quick release coupling is integrated into the clamping system
- Hydraulic ejector: Forces and speeds, multiple stroke (up to 10) and ejector advanced at program end are programmable
- Hydraulic ejector for simultaneous movements regulated with servo valve
- Mould monitoring via ejector platen safety switch
- Electro-mechanical servo drive for ejector system, position controlled for simultaneous drive movements
- Hydraulic core pulls with rapid connect coupling on the movable mould platen
- Hydraulic core pull movement profiles programmable and regulated
- Core holding pressure manually adjustable
- Pressure hold programmable
- Hydraulic core pull, simultaneous movements regulated
- Controlled hydraulic unscrewing units for threaded cores in one or two directions of rotation for mounting on fixed or movable clamping platen. Restricted ejector stroke
- Unscrewing unit with electro-mechanical servo drive for 2-direction threaded cores for installation on the movable clamping platen for ultra-precise positioning and reproducibility. Restricted ejector stroke

- Attachment option for robotic handling device
- Mechanical rapid clamping system with mould support to facilitate mould installation
- Power-operated safety gate, programmable opening time
- Mould blow unit with pressure relief valve
- Sorter unit (SELECTRON)
- Mechanical mould closing protection

Injection unit

- Central injection unit, can be re-positioned and swivelled as a complete assembly
- Plasticising module with universal screw, central coupling and adaptive temperature regulation, available in different diameters
- Thermoplastic cylinder with universal screw in wear resistant execution
- Thermoplastic cylinder complete with very high wear resistant equipment
- Plasticising module for processing thermoset, elastomer and silicone materials
- Thermoplast screws for special applications, e.g. self-dyeing (mixing section), PVC (shear-sensitive), POM, PA (semi-crystalline)
- Programmable nozzle speeds (advance 2, retract 1 stage) and advance and retract delay
- Monitored nozzle contact
- Continuous nozzle contact during the complete cycle
- Programmable nozzle contact force
- Regulated nozzle contact force
- Regulated injection speed profile, 5 steps programmable with injection delay
- Pressure accumulator for very fast injection
- Position-regulated screw (forced movement of injection axis)
- Injection process control with external sensor

- Measurement, display and monitoring of the injection time, switchover volume and switchover pressure
- Switch over to holding pressure as a volume or time dependent function
- Material cushion monitoring
- Holding pressure profile regulated via polygon with 10 base points
- Programmable delay times for all movements
- Screw circumferential speed display
- Positively and negatively programmable back pressure
- Dosage time display with programmable dosage time monitoring
- Dosage possible before or after nozzle retraction
- Material decompression with programmable decompression speed
- Dosage with electro-mechanical servo drive, energy-saving
- Open nozzle with screw-in tip
- Needle type shut off nozzle, spring force actuated
- Needle type shut off nozzle, hydraulically actuated
- Zone-dependent monitoring of heating circuits for continuity, short circuit and defective sensors
- Temperature monitoring with release tolerance range and zone-dependent monitoring tolerance
- Automatic temperature sink can be selected on error or after automatic switch off
- 50 litre corrosion proof stainless steel material hopper movable to a blocking and emptying position
- Granulate feed zone, programmable and regulated with monitoring

Extended functions

- Extended monitoring of the mechanical sequence of mould and machine for complex applications

- Extended drive movements: Increase in number of movement stages, intermediate stop functions and extended locking force program
- Production control with nominal temperature value control, programmable alarm cycles, programmable switch-on / switch-off sequences as well as time-controlled automatic switch-on/off in second programming level for follow-up batch

Regulated parameters

- Control cabinet temperature
- Hydraulic oil temperature
- Plasticising cylinder temperature (adaptive)
- Screw rotation speed
- Injection flow or injection speed
- Holding pressure
- Movements and force of mould, nozzle and ejector
- Ramp control sequence for mould, ejector and nozzle end position
- Back pressure
- Electrical mould heating circuits (adaptive)
- Mould cooling circuits
- Internal cavity pressure or screw chamber pressure (external sensor)
- Nozzle contact force
- Screw position
- Granulate feed zone temperature
- Ejector

ARBURG robotic systems

- INTEGRALPICKER V: vertical sprue picker operating from above, pneumatic drive
- MULTILIFT H: robotic system operating horizontally from the rear of the machine with pneumatic drives (Z-axis optional with servo-electric drive)
- MULTILIFT V: robotic system operating vertically from above (longitudinal and transverse installation possible) with 3 servo-electric axes

- Basic machine
- Options

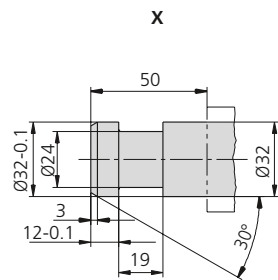
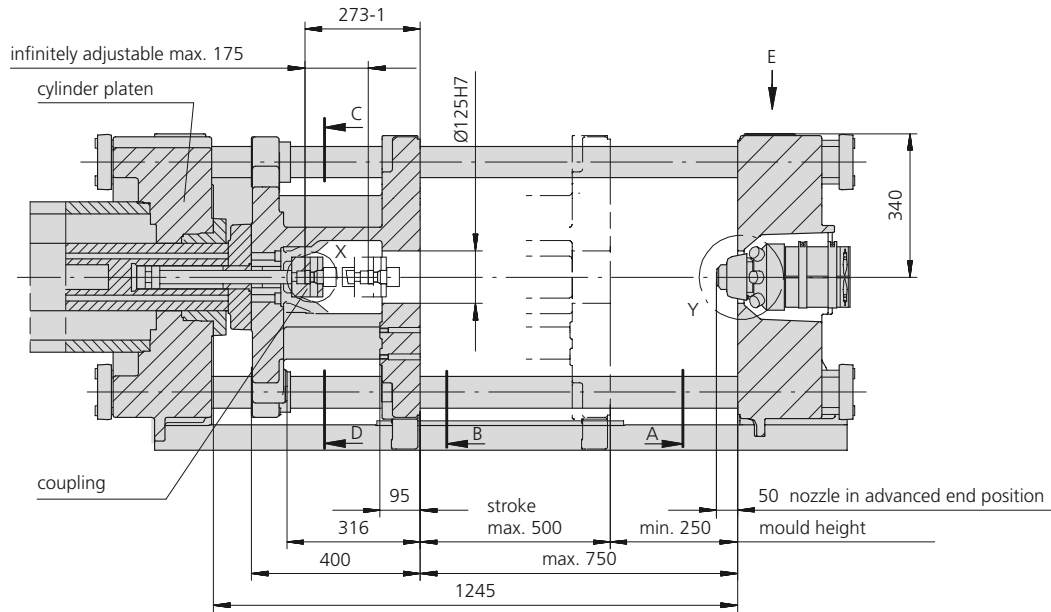

ejector bolt

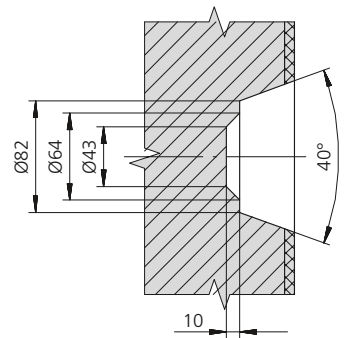

counter bore in the mould required only for short sprue

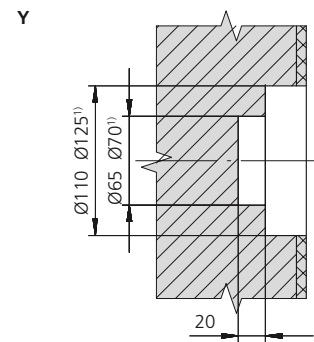

dimensions for thermoset moulds

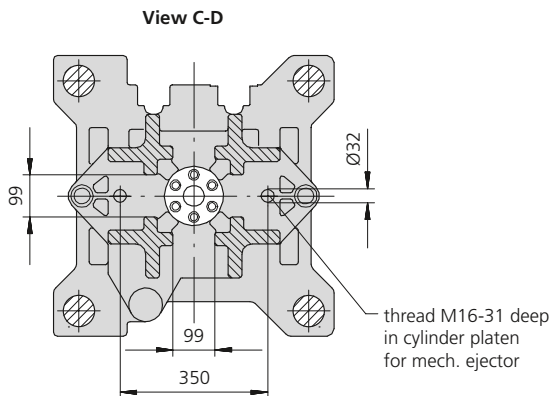

thread M16-31 deep in cylinder platen for mech. ejector

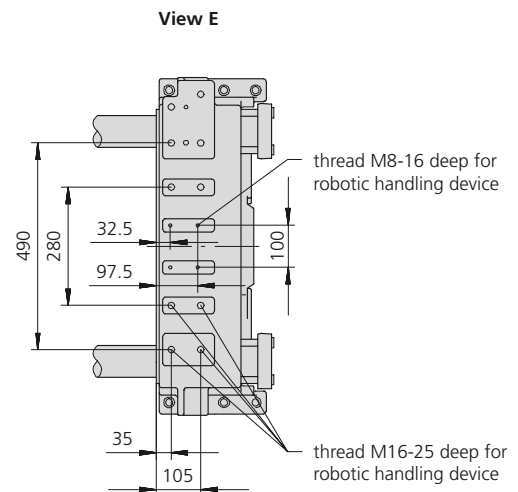

1) Dimensions valid for injection unit 800 in thermoset version

Fixed platen

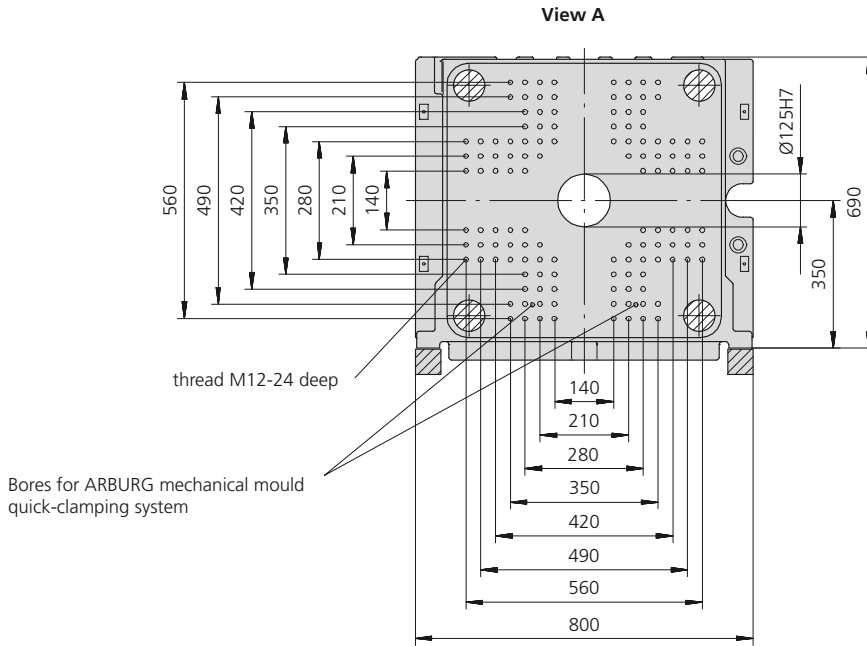

Movable platen

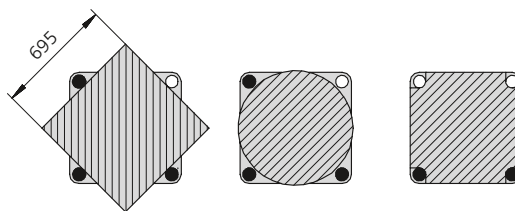
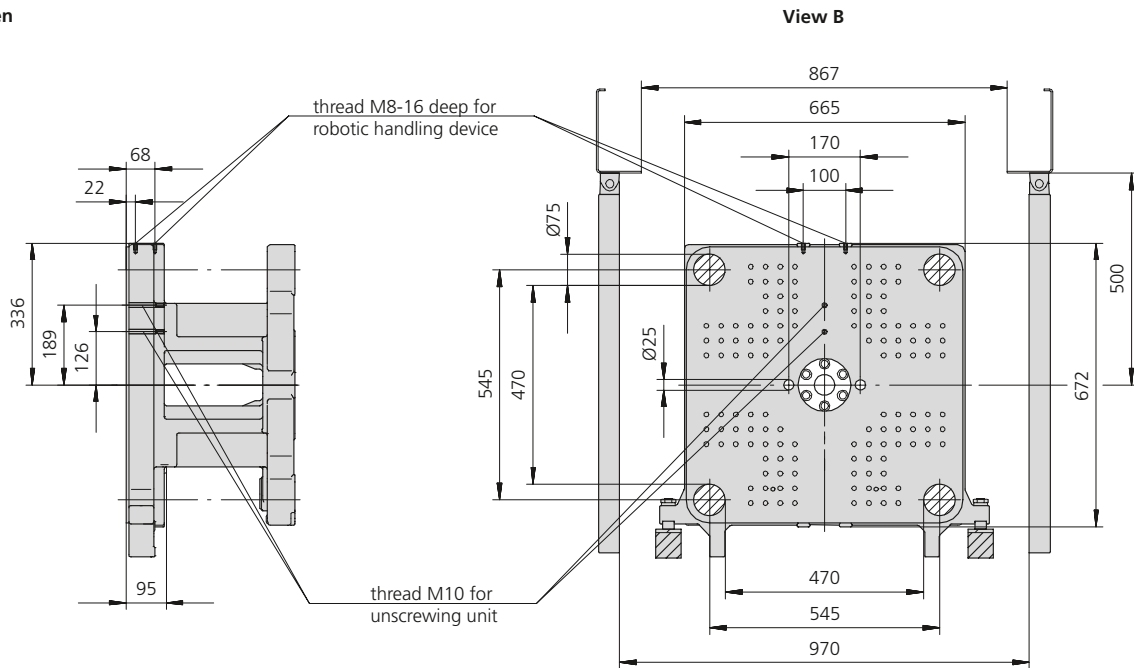

Useable mounting surface with tie bars removed

Maximum theoretical shot weights for the most important injection moulding materials (in grams)

| Injection units according to EUROMAP | | 350 | 800 | | | | |
|--------------------------------------|-------------------------------|-----|-----|-----|-----|-----|-----|
| Screw diameter | mm | 35 | 40 | 45 | 45 | 50 | 55 |
| Polystyrene | PS | 127 | 166 | 210 | 291 | 359 | 434 |
| Styrene heteropolymerizates | SB | 124 | 162 | 205 | 284 | 350 | 424 |
| | SAN, ABS ¹⁾ | 122 | 160 | 202 | 278 | 344 | 416 |
| Cellulose acetate | CA ¹⁾ | 143 | 187 | 237 | 327 | 404 | 488 |
| Celluloseacetobutyrate | CAB ¹⁾ | 133 | 174 | 220 | 304 | 375 | 454 |
| Polymethyl methacrylate | PMMA | 132 | 172 | 218 | 300 | 371 | 449 |
| Polyphenylene ether, mod. | PPE | 118 | 154 | 195 | 270 | 333 | 403 |
| Polycarbonate | PC | 134 | 175 | 221 | 305 | 377 | 456 |
| Polysulphone | PSU | 138 | 181 | 229 | 316 | 390 | 471 |
| Polyamides | PA 6.6, PA 6 ¹⁾ | 127 | 165 | 209 | 289 | 357 | 431 |
| | PA 6.10, PA 11 ¹⁾ | 118 | 154 | 195 | 270 | 333 | 403 |
| Polyoximethylene (Polyacetal) | POM | 157 | 205 | 260 | 359 | 443 | 536 |
| Polyethylene terephthalate | PET | 152 | 198 | 251 | 346 | 427 | 517 |
| Polyethylene | PE-LD | 96 | 126 | 159 | 219 | 271 | 328 |
| | PE-HD | 99 | 130 | 164 | 227 | 280 | 339 |
| Polypropylene | PP | 101 | 133 | 168 | 232 | 286 | 346 |
| Fluoropolymerides | FEP, PFA, PCTFE ¹⁾ | 204 | 266 | 337 | 465 | 574 | 695 |
| | ETFE | 178 | 232 | 294 | 406 | 501 | 606 |
| Polyvinyl chloride | PVC-U | 154 | 201 | 254 | 351 | 434 | 525 |
| | PVC-P ¹⁾ | 142 | 186 | 235 | 324 | 401 | 485 |

1) average value

ARBURG GmbH + Co KG

Postfach 11 09 · 72286 Lossburg · Tel.: +49(0)7446 33-0 · Fax: +49(0)7446 33-3365 · www.arburg.com · e-mail: contact@arburg.com

With locations in | Europe: Germany, Belgium, Denmark, France, United Kingdom, Italy, Netherlands, Austria, Poland, Switzerland, Slovakia,Spain, Czech Republic, Turkey, Hungary | **Asia:** People's Republic of China, Indonesia, Malaysia, Singapore, Thailand | **America:** Brazil, Mexico, USAFor more information, please go to **www.arburg.com**.

© 2008 ARBURG GmbH + Co KG

The brochure is protected by copyright. Any utilisation, which is not expressly permitted under copyright legislation, requires the previous approval of ARBURG.

All data and technical information have been compiled with great care. However, we are unable to guarantee its correctness. Individual illustrations and information may deviate from the actual delivery condition of the machine. The relevant valid operating instructions are applicable for the installation and operation of the machine.

**ARBURG GmbH + Co KG Quality:**

DIN EN ISO 9001 + 14001 certified