

# UN350A5-EU Specifications



## STANDARD FEATURES

- › World famous Austrian made KEBA 1075 Microprocessor control
- › Control of oil temperature from the Keba controller
- › Oil level monitoring
- › Injection hold changeover by time, distance or pressure
- › Control of barrel throat temperature via the Keba controller
- › Semi-auto start button on a flying lead with magnetic base
- › European linear transducers
- › European seals
- › European hydraulic valves
- › European switchgear
- › Back pressure controlled by proportional valve
- › Water manifold with 6 circuits
- › 2 x air-blast circuits fitted with pneumatic valves fitted
- › Double core pull
- › Euomap 67 interface
- › 2 x UK style 13 amp sockets
- › Industry 4.0 ready
- › Ejector safety circuit
- › Oil preheating circuit
- › Servo motor energy saving pump system
- › CE certification
- › Anti-vibration mounts
- › Spares package
- › Tool kit & mould clamps
- › 3 x auxillary three phase sockets.

## OPTIONAL FEATURES

- › Increased clamping force
- › Increased / Decreased mould height
- › Hydraulic or pneumatic valve gate control
- › Integral hot runner control
- › Bi-metallic plasticising units
- › Infrared heater bands
- › Electric screw drive (220t - 700t)
- › Screw designs for PET, PA, PC, PMMA, TPU, UPVC.
- › Accumulator injection
- › Liquid silicone rubber conversion
- › Robots & Ancillaries

INJECTION UNIT		1269/3500			1885/35300			2693/3500		
		A	B	C	A	B	C	A	B	C
Screw diameter	mm	53	60	68	60	68	76	68	76	84
Shot volume	cm <sup>3</sup>	584.6	749.3	962.4	834	1071.3	1338.2	1198.4	1497	1828.8
Shot weight (PS)	g	537.8	689.4	885.4	767.3	985.6	1231.1	1102.5	1377.2	1682.5
Injection pressure	MPa	217.1	169.4	131.8	226.2	176.1	141	224.8	179.9	147.3
Screw L:D ratio		22.6:1	20:1	20:1	22.6:1	20:1	20:1	22.3:1	20:1	20:1
Injection rate	g/s	304	390	501	292	376	469	291	363	444
Max. injection speed	mm/s		152			114			87	
Screw stroke	mm		265			295			330	
Screw speed (stepless)	r/min		0 - 313			0 - 250			0 - 156	
CLAMPING UNIT										
Clamping force	kN	3500								
Platen size	mm	1080 x 1030								
Distance between tie-bars	mm	760 x 710								
Mould thickness (min-max)	mm	240 - 730								
Opening stroke	mm	700								
Max. daylight	mm	1430								
Ejector force	kN	110								
Ejector stroke	mm	210								
Ejector number	PCS	13								
ELECTRICAL & HYDRAULIC UNITS										
Hydraulic system pressure	MPa	17.5								
Oil pump motor	kW	55.4								
Heating capacity	kW	16.6 / 19			22.2 / 24.6			26.4 / 30.9		
Number of temp control zones		5			5			6		
GENERAL										
Dry cycle time	s	4								
Oil tank capacity	L	570								
Machine dimensions (LxWxH)	mm	7770 x 2300 x 2450								
Max. mould weight - moving	kg	2667								
Max. mould weight - fixed	kg	1333								
Machine weight	kg	15200								

## MOVING PLATEN DRAWINGS

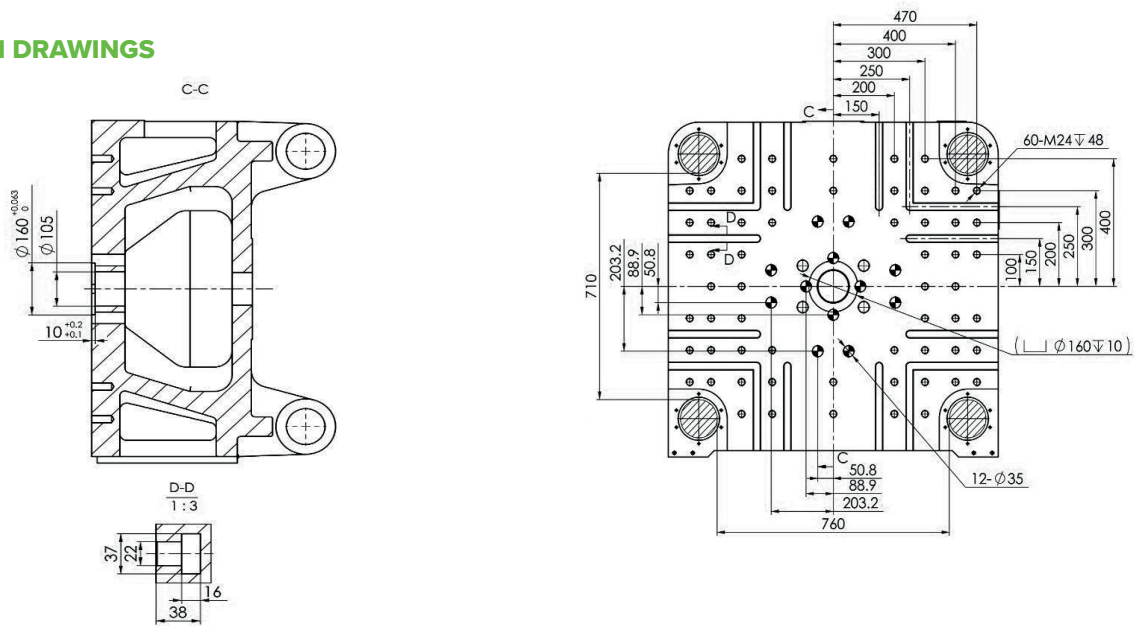

## FIXED PLATEN DRAWINGS

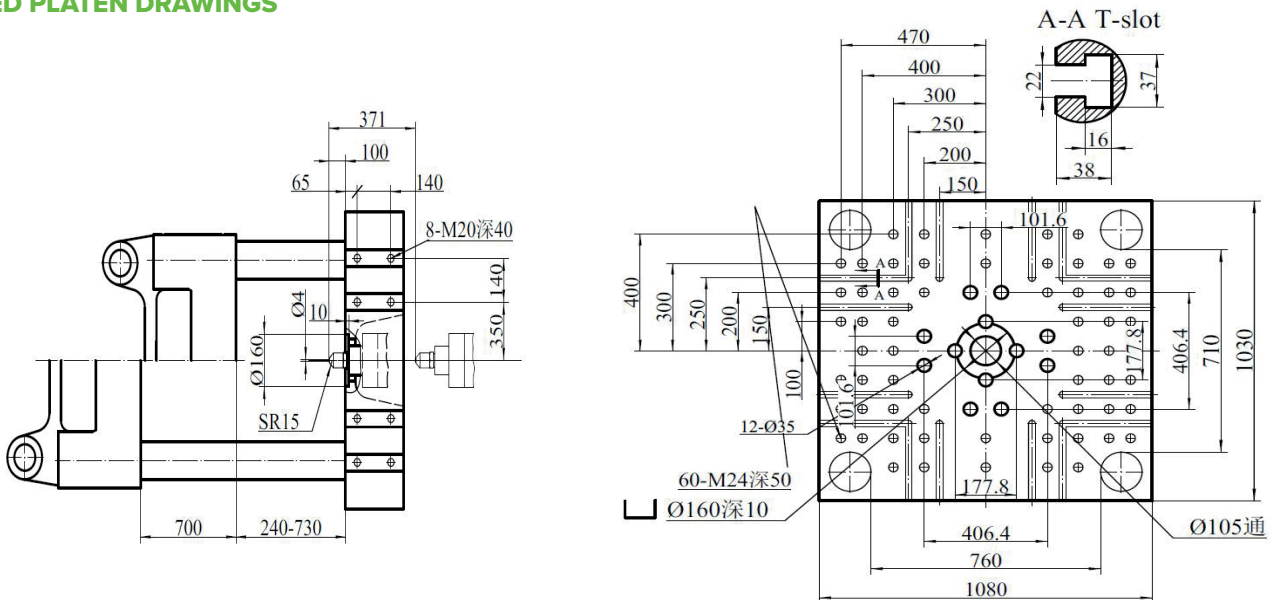

## MACHINE DIMENSIONS

