

## Screenless Granulators

SG-24 series of screenless granulators are suitable for granulating hard and thick, long and thin plastic wastes or by-the-press recycling of sprues at low capacity. With "Euro" style appearance and compact size, they feature low speed, low noise level, and high torque. Unique cutting blades design ensure well-proportioned granules and minimal amount of dusts. All parts are accessible for cleaning and maintenance. They are also easy and safe to operate, and can ensure excellent performance.

### Features:

- German-made gear motor features reliable performance, long life and high torque.
- They feature integral design of teeth cutters and cutting blades. Staggered blades make the initial cutting and teeth cutters reduce the materials into desired size. Regrinds could be used with virgin materials.
- Screenless design, low speed, low noise level and low energy consumption.
- Unique synchronous transmission belt ensure smooth running of the machine and low noise level.
- When motor blockage occurs, the machine will alarm visibly and enable motor reverse function. It resumes normal operation automatically after the trouble is clear.
- "Euro" style appearance, compact in size and easy to access for cleaning and maintenance.
- Transparent acryl-glass feeding hopper.

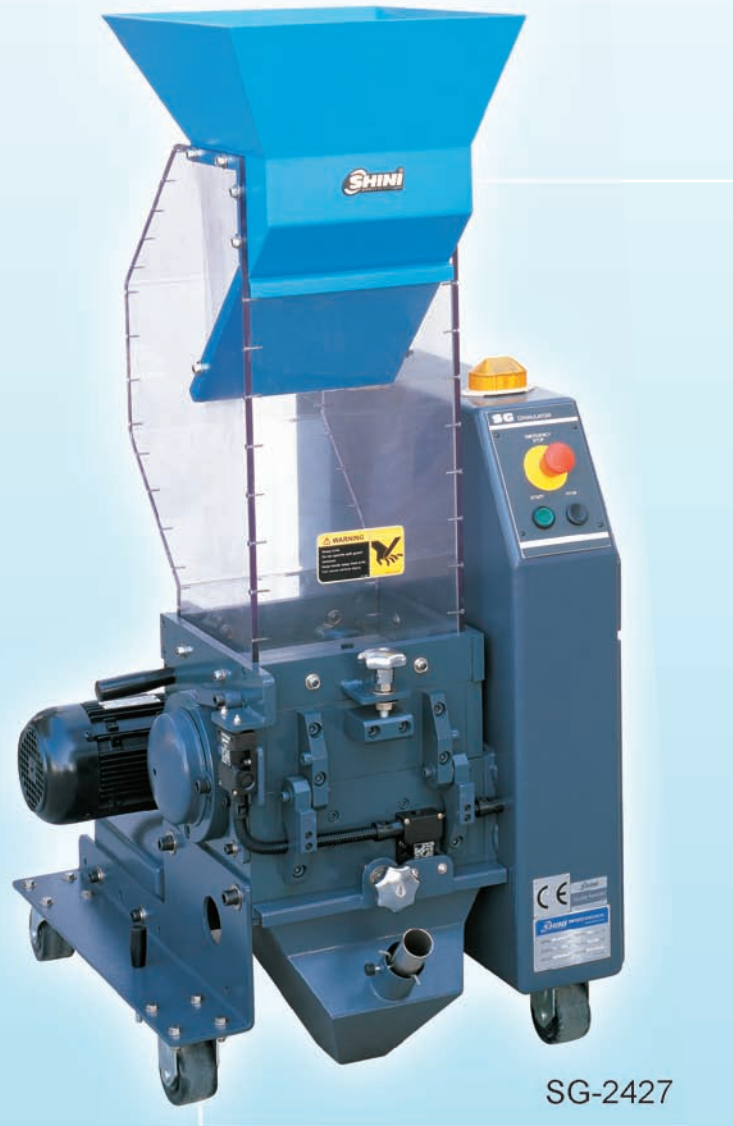

Tech cutter

## Specifications

Model	SG-2417	SG-2427	SG-2427H	SG-2436	SG-2436H	SG-2446
Motor power (kw) (50/60Hz)	0.75 / 0.9	0.75 / 0.9	1.5 / 1.8	1.5 / 1.8	2.2 / 2.64	2.2 / 2.64
Rotor speed (rpm) (50/60Hz)	26 / 32	26 / 32	26 / 32	26 / 32	26 / 32	26 / 32
Number of cutting blade(s)	1	2	2	3	3	4
Number of teeth cutters	2	3	3	4	4	5
Cutting chamber (mm)	242 × 174	242 × 270	242 × 270	242 × 366	242 × 366	242 × 462
Max. throughput capacity (kg/hr) (50/60Hz)	8 / 10	12 / 14	12 / 14	16 / 19	16 / 19	20 / 24
Noise level dB(A)	65	65	65	67	67	84
Material of teeth cutters	SKD-11	SKD-11	SKD-11	SKD-11	SKD-11	SKD-11
30 secs. instant recycling	○	○	○	○	○	○
Proportioning valve	○	○	○	○	○	○
Manual storage bin	○	○	○	○	○	○
Level detector	○	○	○	○	○	○

## Dimensions

A (mm)	290	386	386	482	482	578
B (mm)	449	449	449	449	449	449
C (mm)	835	835	835	835	835	835
H (mm)	1335	1335	1335	1335	1335	1335
L (mm)	700	700	700	700	700	700
W (mm)	480	576	576	672	672	768
Weight (kg)	270	310	310	343	343	380

Note: 1) "○" optional

- 2) Max. Capacity of the machine is subject to the size and composition of the material.
- 3) Noise level will vary with different materials.
- 4) SKD-11 is material code number of Japanese JIS standard.
- 5) Teeth cutter blades 5mm width as standard, 4mm and 6mm as optional.
- 6) Power supply: 3Φ, 230/400/460/575V, 50/60Hz.

We reserve the right to change specifications without prior notice.

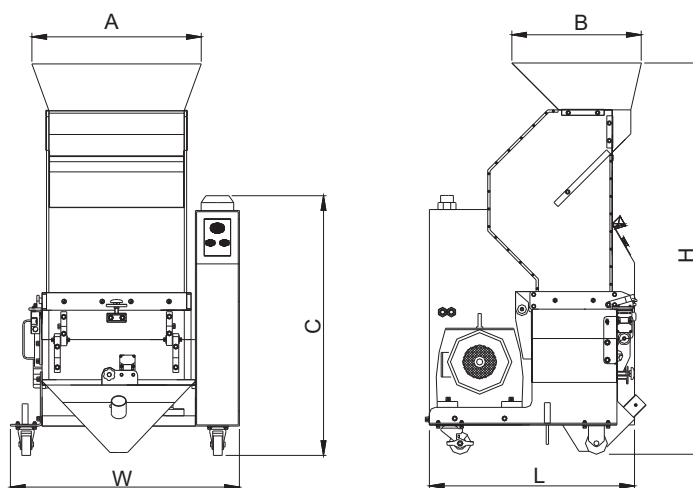

## Shini Plastics Technologies, Inc.

### Corporate Strategic Center:

Jinshagang Industrial Zone, Dalang,

Dongguan, Guangdong, P.R. China.

Telephone: +86 (0)769 8331 3588

Facsimile: +86 (0)769 8331 3589

Email: [shini@shini.com](mailto:shini@shini.com)

[www.shini.com](http://www.shini.com)

# STV Group

The plastics machinery specialist

*STV provides an outstanding range of plastics machinery from all over the world, plus a wealth of application expertise, to help you get the most out of your investment. We aim to provide quality, value-for-money and reliable support services throughout the life of your machines.*

*From our base in Milton Keynes, Buckinghamshire, we serve customers throughout the UK and Eire.*

*The STV Group brings together all these leading brands:*



### **Beam robots, sprue pickers, robot tooling**

One of the world's leading manufacturers of industrial robots, Apex offers exceptional performance and value, endorsed by thousands of users worldwide.

**Telephone:** 01908 616544 **www.apexrobot.co.uk**

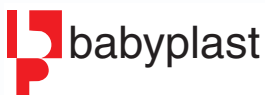

### **Micro-moulding and two shot machines**

Babyplast is a pioneer in micro-moulding with a range of stand-alone machines and add-on injection units allowing multi-component moulding with standard machines.

**Telephone:** 01908 616704 **www.babyplast.net**



### **Plastic processing ancillaries**

The Shini line-up includes a huge range of high quality dryers, loaders, granulators, proportioning valves and more — at prices you simply won't believe.

**Telephone:** 01908 616774 **www.shini.co.uk**

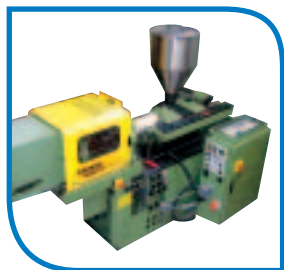

### **Pre-owned plastic machinery**

Our highly successful used plastics machinery website connects buyers and sellers directly, allowing both parties to strike the best deals.

**Telephone:** 01908 616534 **www.stvconnect.co.uk**

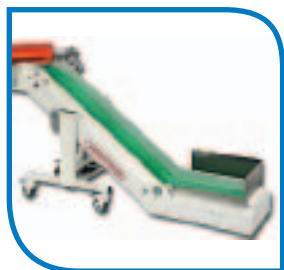

### **Conveyors, separators, box fillers, mixers**

Choose from a range comprising hundreds of standard models, or use our custom build services to build to your own specification.

**Telephone:** 01908 514068 **www.virgionionastri.co.uk**

