

# UN60A5-EU Specifications

## STANDARD FEATURES

- World famous Austrian made KEBA 1075 Microprocessor control
- Control of oil temperature from the Keba controller
- Oil level monitoring
- Injection hold changeover by time, distance or pressure
- Control of barrel throat temperature via the Keba controller
- Semi-auto start button on a flying lead with magnetic base
- European linear transducers
- European seals
- European hydraulic valves
- European switchgear
- Back pressure controlled by proportional valve
- Water manifold with 6 circuits
- 2 x air-blast circuits fitted with pneumatic valves fitted
- Double core pull
- Euomap 67 interface
- 2 x UK style 13 amp sockets
- Industry 4.0 ready
- Ejector safety circuit
- Oil preheating circuit
- Servo motor energy saving pump system
- CE certification
- Anti-vibration mounts
- Spares package
- Tool kit & mould clamps
- 3 x auxillary three phase sockets.



## OPTIONAL FEATURES

- Increased clamping force
- Increased / Decreased mould height
- Hydraulic or pneumatic valve gate control
- Integral hot runner control
- Bi-metallic plasticising units
- Infrared heater bands
- Electric screw drive (220t - 700t)
- Screw designs for PET, PA, PC, PMMA, TPU, UPVC.
- Accumulator injection
- Liquid silicone rubber conversion
- Robots & Ancillaries

INJECTION UNIT		190/600		295/600		
		A	B	A	B	C
Screw diameter	mm	22	26	30	35	40
Shot volume	cm <sup>3</sup>	51.2	71.6	116.6	159	207
Shot weight (PS)	g	47	65.9	107	146	190.4
Injection pressure	MPa	373	267	252.8	185.6	142.2
Screw L:D ratio		20:1	20:1	24:1	20:1	20:1
Injection rate	cm <sup>3</sup> /s	42.5	59.4	69.6	94.8	123.5
Max. injection speed	mm/s	123		107		
Screw stroke	mm	135		165		
Screw speed (stepless)	r/min	0 - 230		0 - 219		
CLAMPING UNIT						
Clamping force	kN	600				
Platen size	mm	560 x 560				
Distance between tie-bars	mm	360 x 360				
Mould thickness (min-max)	mm	130 - 380				
Opening stroke	mm	330				
Max. daylight	mm	710				
Ejector force	kN	28				
Ejector stroke	mm	100				
Ejector number	PCS	5				
ELECTRICAL & HYDRAULIC UNITS						
Hydraulic system pressure	MPa	17.5				
Oil pump motor	kW	11				
Heating capacity	kW	4.8 / 5.5		6.9 / 7.8		
Number of temp control zones		4		4		
GENERAL						
Dry cycle time	s	1.8				
Oil tank capacity	L	150				
Machine dimensions (LxWxH)	mm	4490 x 1590 x 1880				
Max. mould weight - moving	kg	360				
Max. mould weight - fixed	kg	180				
Machine weight	kg	3300				

## MOVING PLATEN DRAWINGS

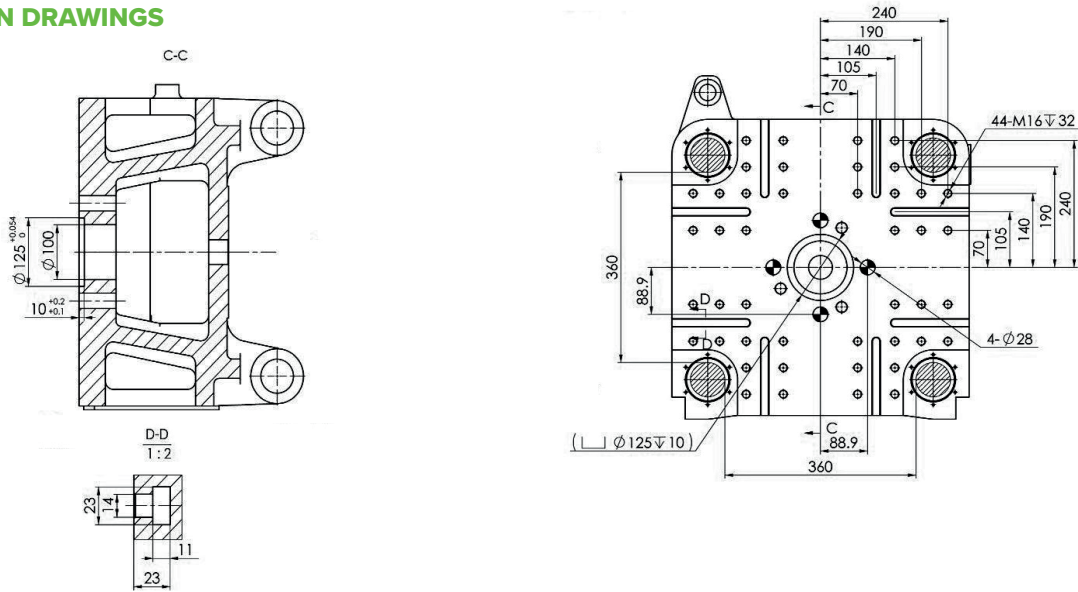

## FIXED PLATEN DRAWINGS

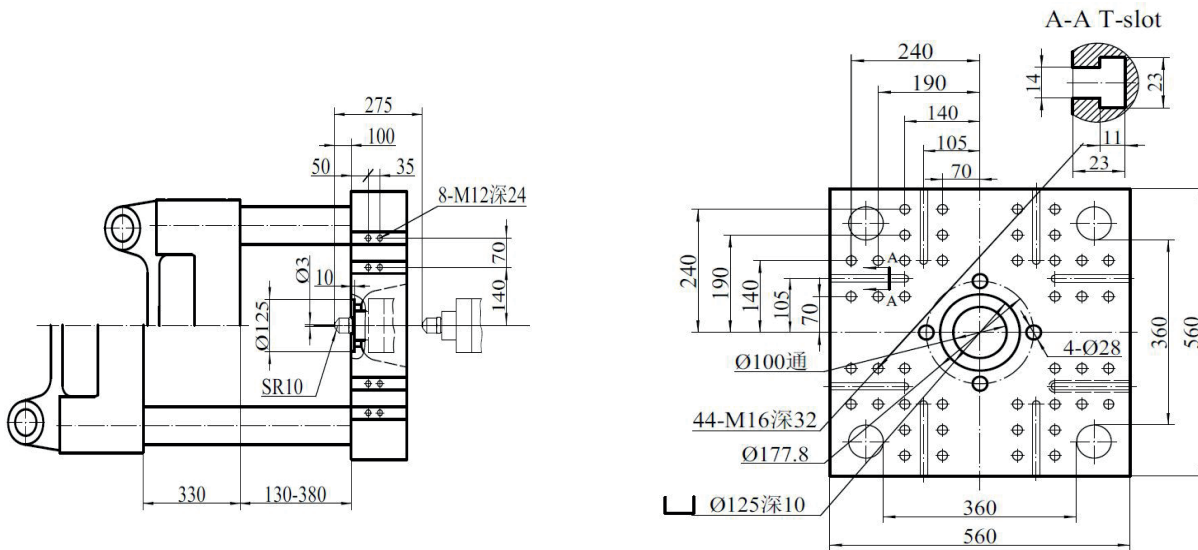

## MACHINE DIMENSIONS

